



Unitary Side Discharge Split System 24VAC Control

Submittal Data: FLEXX48/60HP230V1A 48000 BTU/H (208/230V) HEAT PUMP SYSTEM

Job Name _____ Location _____ Date _____

Purchaser _____ Engineer _____

Submitted To _____ For Reference Approval Construction

Unit Designation _____ Schedule No. _____

- GENERAL FEATURES**
- Side Discharge Outdoor Unit
 - Zero Lot Line Design
 - Match with Gree or Competitive Indoor Unit
 - Designed for New Construction or Replacement Market
 - Quiet Outdoor Operation - 55 dB(A)
 - 24VAC Thermostat Compatible
 - Acrylic Resin/Anti-Corrosion Fin Coating
 - 5 yr. Limited Compressor & Parts Warranty (Residential Only)



System Ratings

Cooling	
Rated Capacity (BTU/H)	48000
Capacity Range (BTU/H)	34000-50000
Power Input (W)	4360
SEER	18
EER	11
Heating at 47° F	
Rated Capacity (BTU/H)	48000
Capacity Range (BTU/H)	34000-52000
Power Input (W)	3910
HSPF	10.5
COP	3.6
Heating at 17° F	
Rated Capacity (BTU/H)	33000
Operating Range	
Cooling	(Max) 129°F (46°C) (Min) 5°F (-18°C)
Heating	(Max) 75°F (24°C) (Min) -22°F (-30°C)
Refrigerant Piping Data	
Gas Pipe Size - OD (in)	3/4
Liquid Pipe Size - OD (in)	3/8
Connection Method	Brazed
Factory Charge (oz)	220.8
Additional Charge (oz/ft)	0.3
Factory Charge Length (ft)	25
MAX Refrigerant Pipe Length (ft)	98
MIN Refrigerant Pipe Length (ft)	15
MAX Refrigerant Pipe Elevation (ft)	49

Indoor Unit Data - FLEXX48HP230V1AH

Fan Motor	Output Power (HP)	1
	FLA (A)	3.2
Airflow	CFM	1470
	Rated External Static Pressure	0.2
	External Static Pressure Range (InWg)	0-.4
	Sound Pressure Level (dB(A))	50
Dehumidification (pt/hr)		7
Power Supply (Dedicated Circuit: Size Per Local Code)		
	Normal Operational Voltage	208/230 V, 1 Phase, 60 Hz
	Voltage Range	187 - 253 V
	MCA (A)	4
	MOCP/Breaker Size (A)	15

Outdoor Unit Data - FLEXX60HP230V1AO

Compressor	DC Inverter Driven Rotary	
	RLA (A)	19
Refrigerant Type		R410A
Fan Motor	Output Power (HP)	1/5 x 2
	FLA (A)	1.5 x 2
Crankcase Heater (W)		40
Sound Pressure Level - dB(A)		58
Power Supply (Dedicated Circuit: Size Per Local Code)		
	Normal Operational Voltage	208/230 V, 1 Phase, 60 Hz
	Voltage Range (V)	187 - 253
	MCA (A)	35
	MOCP/Breaker Size (A)	45

SYSTEM FEATURES	
Compressor	Inverter
Ultra Low Frequency Torque Control	YES
Power Factor Correction	YES
Compressor Type	Rotary
Refrigerant Type	R410A
Outdoor Electronic Expansion Valve (EEV)	YES
Indoor TXV Control	YES
Basepan With Electric Heater	YES
Compressor With Electric Heater	YES
Outdoor Fin Coating	Acrylic Resin
Intelligent Defrosting	YES
Intelligent Preheating	YES
Low Voltage Startup	YES
Memory/Power Failure Recovery	YES
Self Diagnosis	YES
Low Ambient Cooling	YES
24VAC Thermostat Compatible	YES
Indoor Fan Type	Centrifugal
Multi Fan Speeds	3 Speeds
Auxiliary Electrical Heater	Optional

FAN PERFORMANCE CURVES

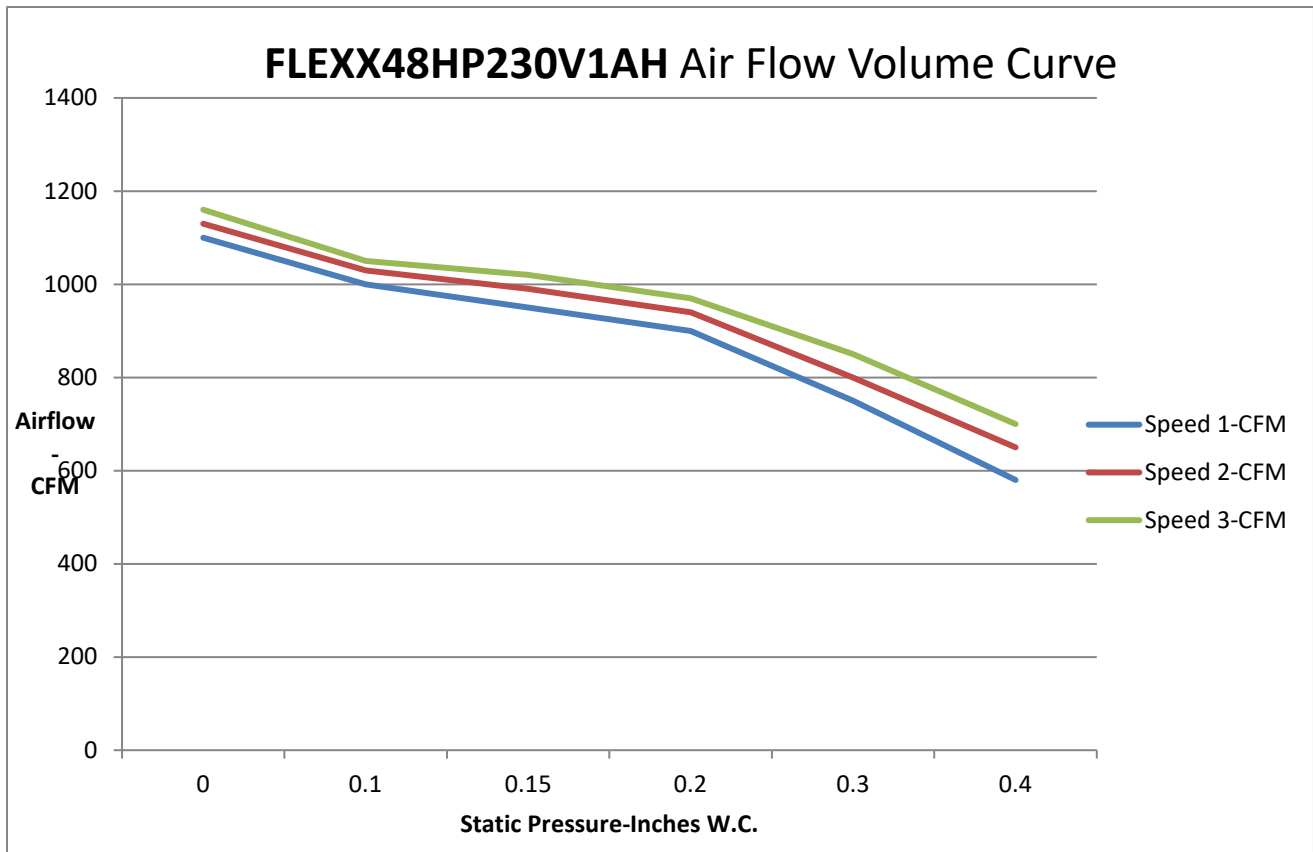

Static Pressure - InWc	0	0.1	0.15	0.2	0.3	0.4
Speed 1-CFM	1100	1000	950	900	750	580
Speed 2-CFM	1130	1030	990	940	800	650
Speed 3-CFM	1160	1050	1020	970	850	700

COOLING PERFORMANCE

Outdoor Ambient Temperature (DB)		Return Air Temperature											
		60 (15°C)				70 (21°C)				80°F (27°C)			
		Capacity	Input Power (watts)	EER	SHC	Capacity	Input Power (watts)	EER	SHC	Capacity	Input Power (watts)	EER	SHC
50°F	29640	2720	10.89	21040	38760	3230	12	27520	45600	3400	13.41	32370	
65°F	31200	3000	10.4	22150	40800	3560	11.45	28970	48000	3750	12.80	34080	
75°F	31200	3080	10.12	22150	40800	3650	11.15	28970	48000	3850	12.47	34080	
85°F	31200	3240	9.62	22150	40800	3850	10.6	28970	48000	4050	11.85	34080	
95°F	31200	3480	8.96	22150	40800	4130	9.87	28970	48000	4350	11.03	34080	
105°F	31200	4240	7.35	22150	40800	5030	8.1	28970	48000	5300	9.06	34080	
115°F	28270	3880	7.27	20070	36970	4610	8	26250	43500	4860	8.95	30880	

HEATING PERFORMANCE

Outdoor Ambient Temperature (DB)		Return Air Temperature											
		60 (15°C)				70 (21°C)				80 (27°C)			
		TC (BtuH)	Input Power (watts)	COP		TC (BtuH)	Input Power (watts)	COP		TC (BtuH)	Input Power (watts)	COP	
-22°F	26660	5580	4.77		26400	5700	4.63		25870	5750	4.49		
-15°F	28780	5780	4.97		28500	5900	4.83		27930	5960	4.68		
-5°F	34540	6070	5.68		34200	6200	5.52		33510	6260	5.35		
5°F	40900	6470	6.32		40500	6600	6.14		39690	6660	5.95		
17°F	48480	5980	8.1		48000	6100	7.87		47040	6160	7.63		
32°F	48480	5680	8.52		48000	5800	8.28		47040	5860	8.03		
47°F	50500	4360	11.57		50000	4450	11.24		49000	4490	10.9		
60°F	52520	4560	11.52		52000	4650	11.18		50960	4690	10.8		

LEGEND

DB --- Dry Bulb

WB --- Wet Bulb

TC --- Total Capacity (BtuH)

SC --- Sensible Capacity (BtuH)

Input Power---(Watts)

COP---Coefficient Of Performance

Specifications are subject to change without notice. Manufacturer reserves the right to discontinue or modify specifications or designs without notice or without incurring obligations. All rights reserved.

Submittal Data: FLEXX48HP230V1AH

MINIMUM SPACING REQUIREMENTS

Units: inches

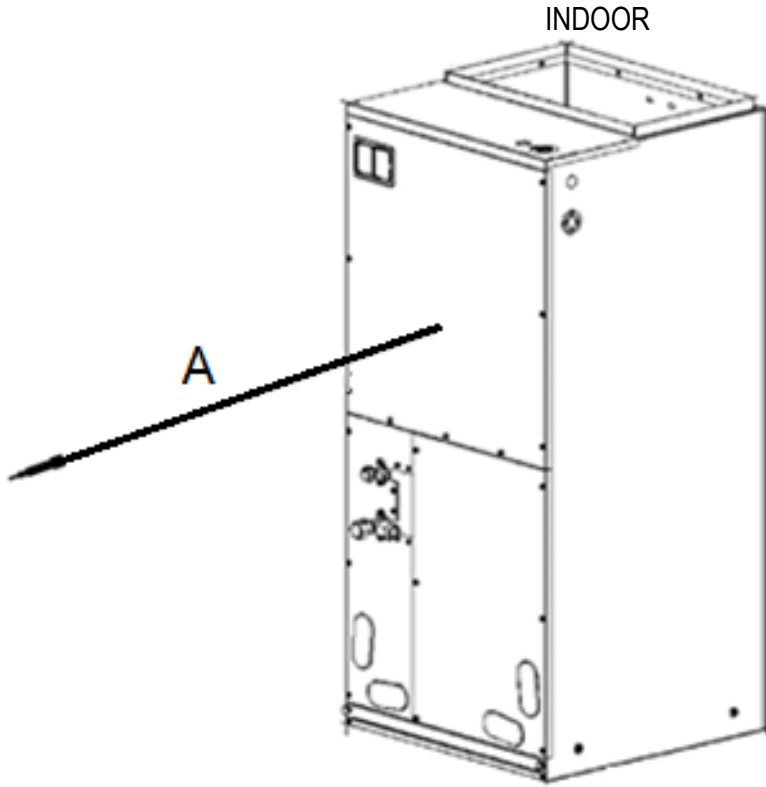

A	24
ALL OTHER SIDES	0

ALWAYS CHECK AND FOLLOW STATE AND LOCAL CODE REGULATIONS FOR MINIMUM SPACING REQUIREMENTS

FLEXX60HP230V1AO

MINIMUM SPACING REQUIREMENTS

Units: inches

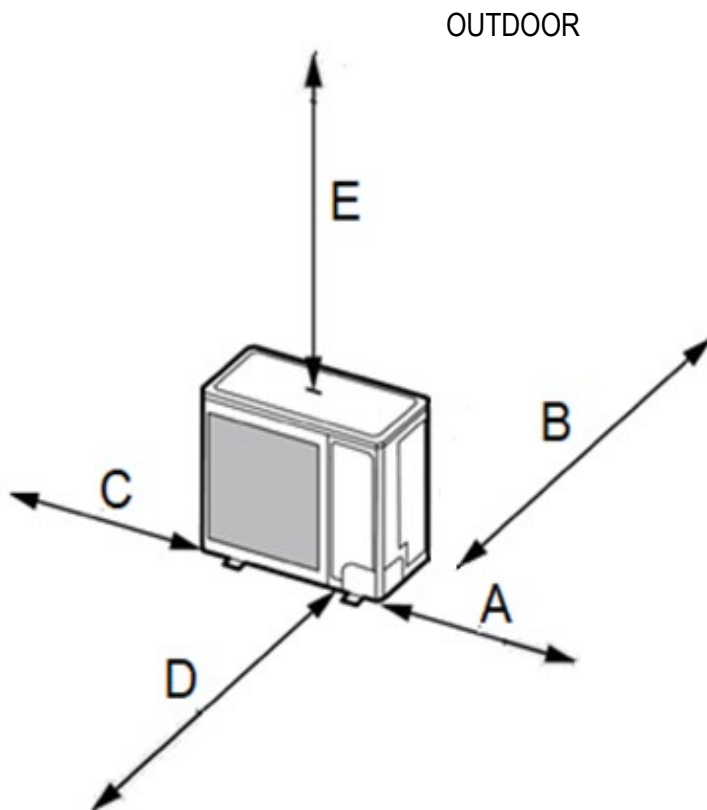

A	12
B	4
C	4
D	40
E	40

ALWAYS CHECK AND FOLLOW STATE AND LOCAL CODE REGULATIONS FOR MINIMUM SPACING REQUIREMENTS

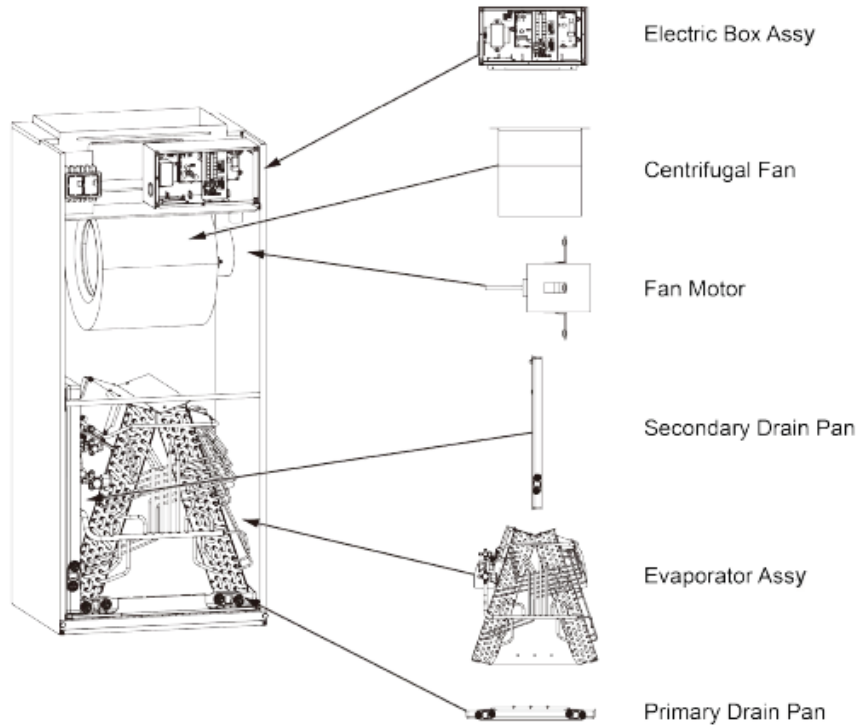

Model	Cooling Capacity (ton)	Optional Electric Heater	KW
FLEXX36,48,60HP230V1AH	3.0 / 4.0 / 5.0	FLEXXHTR10KW	10
FLEXX48,60HP230V1AH	4.0 / 5.0	FLEXXHTR15KW	15
FLEXX48,60HP230V1AH	4.0 / 5.0	FLEXXHTR20KW	20

Power Supply	V	240	240	240	240	240
Rated Power	kW			10	15	20
Min. Circuit Ampacity	A			50	50 & 25	50 & 50
Max. Fuse or Breaker Ampacity	A			60	60 & 30	60 & 60

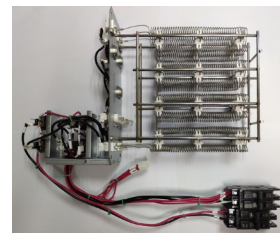
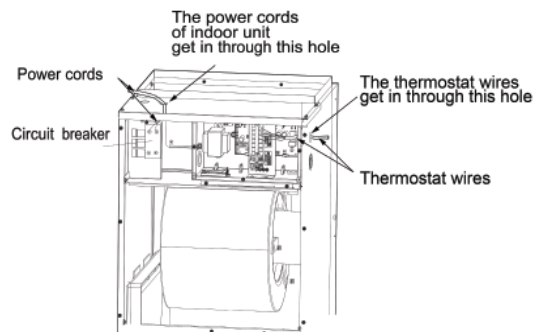

Specifications are subject to change without notice. Manufacturer reserves the right to discontinue or modify specifications or designs

DIMENSIONAL SPECIFICATIONS FLEXX48HP230V1AH

INDOOR UNIT DIMENSIONS & WEIGHTS

Units: inch

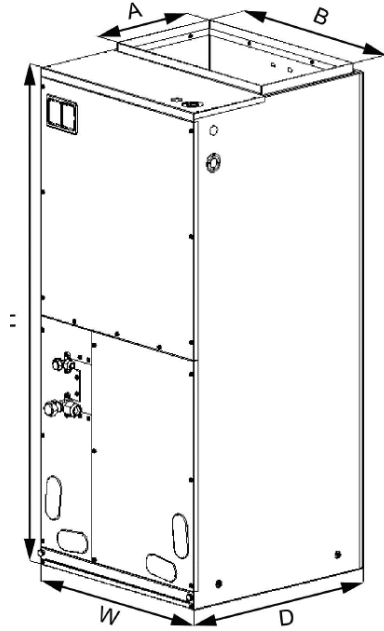

W	24-3/4
D	21-1/4
H	57-1/4
A	11-5/8
B	20

Net Weight (lbs)	202.8
Shipping Weight (lbs)	218

Liquid Line Valve	3/8-in OD Brazed
Gas Line Valve	3/4-in OD Brazed
Drain Connector	3/4 in OD

FLEXX60HP230V1AO

OUTDOOR UNIT DIMENSIONS & WEIGHTS

Units: inch

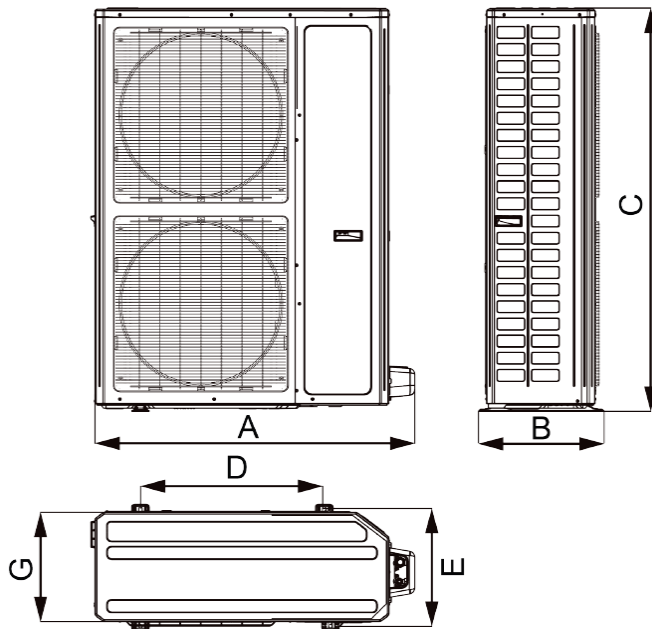

A	42-3/4
B	16-7/8
C	53-3/4
D	24-1/2
E	15-1/2
G	14-1/2

Net Weight (lbs)	308.6
Shipping Weight (lbs)	337

Liquid Line Valve	3/8-in OD Brazed
Gas Line Valve	3/4-in OD Brazed

Notes:

1. Power wiring size must comply with applicable national and local codes for both ID and OD dedicated circuits.
2. Test conditions are based on AHRI 210/240.

Specifications are subject to change without notice. Manufacturer reserves the right to discontinue or modify specifications or designs without notice or without incurring obligations. All rights reserved.