



# D14 Series SEER2 Air Handlers

Cooling capacity: 18 - 60 kBTU/h



## Contents:

1 NOMENCLATURE.....	2
2 SPECIFICATIONS.....	3
3 DIMENSIONS.....	4
4 AIRFLOW DATA.....	5
5 WIRING DIAGRAM .....	8
6 HEATER KITS .....	9



---

## Features:

- Available for cooling and heat pump applications.
- All-aluminum tubes & fins.
- Common Factory-sealed cabinet certified to achieve 2% or less leakage rate at 1.0 inch water column.
- Multi-position Installation.
- Horizontal and vertical condensate drain pans standard.
- Blower and coil easy slide out for ease of maintenance.
- Field Installed heater kits are optional: 5/7.5/10/15/20kW.
- AHRI Listed & ETL Certified.

## 1 Nomenclature

D	14	24	HAE	AL	2
1	2	3	4	5	6

Legend		
No.	Code	Remarks
1	D	DiamondAir
2	14	14 Series
3	24	Tonnage:    18 = 1.5 Ton    24 = 2 Ton    30 = 2.5 Ton    36 = 3 Ton 42 = 3.5 Ton    48 = 4 Ton    60 = 5 Ton
4	HA	Applications: Heat Pump & Central Air
5	E	Revision
6	AL	Aluminum Coil
7	2	SEER2 Compatible

## 2 Specifications

	D1418HAEAL2	D1424HAEAL2	D1436HAEAL2	D1448HAEAL2	D1460HAEAL2
<b>NOMINAL RATING</b>					
Cooling (BTU/h)	18,000	24,000	36,000	48,000	60,000
External Static Pressure(in.w.c)	0.6	0.6	0.6	0.7	0.8
<b>ELECTRICAL DATA</b>					
Voltage / Phase(60Hz)	208/230/1	208/230/1	208/230/1	208/230/1	208/230/1
Min. / Max. Voltage	187/253	187/253	187/253	187/253	187/253
Min. Circuit Amps	1.9	2.9	3.3	4.2	5.7
Max. Overcurrent Protection	15	15	15	15	15
<b>FAN MOTOR</b>					
Motor Type	PSC	PSC	PSC	PSC	PSC
Capacitor (uF)	6	10	10	20	20
Horsepower (HP)	1/5	1/4	1/2	1/2	3/4
Rated RPM	755	903	865	925	990
Full Load Amps (FLA)	1.5	2.3	2.6	3.3	4.5
<b>FAN BLOWER</b>					
Material	Metal	Metal	Metal	Metal	Metal
Type	Centrifugal	Centrifugal	Centrifugal	Centrifugal	Centrifugal
Diameter(in.)	10-5/8	13	13	13	13
Height(in.)	10-3/4	10-5/8	10-5/8	10-5/8	10-5/8
<b>EVAPORATOR COIL</b>					
Type	Tube & Fin	Tube & Fin	Tube & Fin	Tube & Fin	Tube & Fin
Tube Material	Aluminum	Aluminum	Aluminum	Aluminum	Aluminum
Tube Size(in.)	9/32	9/32	9/32	9/32	9/32
<b>REFRIGERANT CONNECTION SIZE</b>					
Liquid Line Size (O.D.)	3/8	3/8	3/8	3/8	3/8
Suction Line Size (O.D.)	3/4	3/4	3/4	7/8	7/8

3 Dimensions

NOTE: 25" CLEARANCE IS REQUIRED IN THE FRONT OF THE UNIT FOR FILTER AND COIL MAINTENANCE.

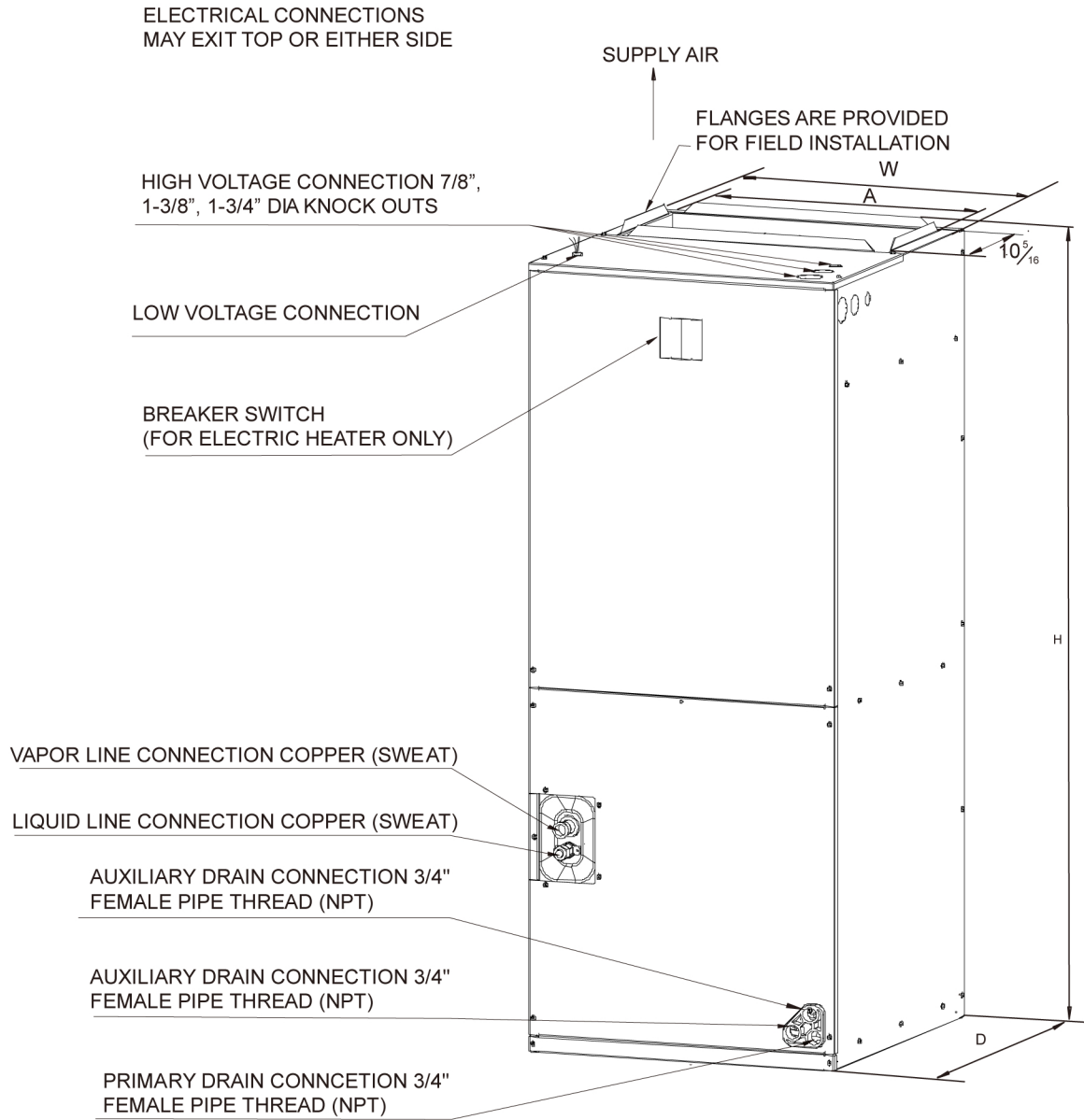

UPFLOW UNIT SHOWN;  
UNIT MAY BE INSTALLED UPFLOW, DOWNFLOW,  
HORIZONTAL RIGHT OR LEFT AIR SUPPLY.

	D1418HAEAL2	D1424HAEAL2	D1436HAEAL2	D1448HAEAL2	D1460HAEAL2
<b>UNIT DIMENSION AND WEIGHTS</b>					
Height(in.)	41-3/8	46-1/2	46-1/2	54-1/2	54-1/2
Width(in.)	18-1/8	19-5/8	19-5/8	22	22
Depth(in.)	20-1/2	21-5/8	21-5/8	24	24
Weight(lbs.)	108	128	128	159	161

4 Airflow Data

Air Handler Model	Outdoor Unit Size(Tons)	Motor Speed		CFM Wet Coil without filter and Electric Heat								
				External Static Pressure-Inches W.C. [kPa]								
				0[0]	0.1[.025]	0.2[.050]	0.3[.075]	0.4[0.100]	0.5[0.125]	0.6[0.150]	0.7[0.175]	0.8[0.200]
18	1.5	Low	CFM	666	634	597	558	506	459	407	326	267
			Watts	210	205	201	196	191	185	178	167	159
			Current/A	0.92	0.89	0.88	0.86	0.84	0.82	0.79	0.75	0.72
		Medium	CFM	855	835	791	744	705	657	586	528	464
			Watts	240	237	232	227	222	215	207	200	191
			Current/A	1.04	1.02	1.01	0.98	0.96	0.94	0.91	0.87	0.84
		High	CFM	980	950	896	869	810	757	687	609	523
			Power/W	308	302	298	293	282	273	262	252	240
			Current/A	1.34	1.31	1.29	1.27	1.23	1.19	1.16	1.117	1.07
24	2	Low	CFM	999	953	905	847	757	681	610	543	411
			Watts	316	310	306	302	288	279	270	256	240
			Current/A	1.38	1.36	1.34	1.32	1.28	1.24	1.21	1.16	1.1
		Medium	CFM	1176	1127	1086	1028	944	842	746	668	569
			Watts	342	336	334	326	315	303	292	281	266
			Current/A	1.49	1.47	1.45	1.42	1.38	1.33	1.29	1.25	1.19
		High	CFM	1409	1359	1306	1253	1192	1108	986	870	743
			Power/W	456	446	438	429	419	404	384	368	348
			Current/A	2.01	1.96	1.93	1.9	1.86	1.8	1.73	1.67	1.61
36	2.5	Low	CFM	1028	985	930	859	781	712	649	571	468
			Watts	362	353	345	335	323	313	303	290	276
			Current/A	1.64	1.62	1.6	1.57	1.54	1.51	1.49	1.45	1.42
		Medium	CFM	1315	1266	1208	1146	1065	981	866	775	686
			Watts	406	399	392	385	372	361	344	331	320
			Current/A	1.82	1.8	1.78	1.75	1.72	1.69	1.65	1.62	1.59
		High	CFM	1532	1478	1421	1347	1284	1184	1082	932	805
			Power/W	524	513	502	491	478	462	446	423	407
			Current/A	2.39	2.36	2.34	2.31	2.28	2.23	2.2	2.14	2.11
36	3	Low	CFM	1028	985	930	859	781	712	649	571	468
			Watts	362	353	345	335	323	313	303	290	276
			Current/A	1.64	1.62	1.6	1.57	1.54	1.51	1.49	1.45	1.42
		Medium	CFM	1315	1266	1208	1146	1065	981	866	775	686
			Watts	406	399	392	385	372	361	344	331	320
			Current/A	1.82	1.8	1.78	1.75	1.72	1.69	1.65	1.62	1.59
		High	CFM	1532	1478	1421	1347	1284	1184	1082	932	805
			Power/W	524	513	502	491	478	462	446	423	407
			Current/A	2.39	2.36	2.34	2.31	2.28	2.23	2.2	2.14	2.11

Model Number	Outdoor Unit Size(Tons)	Motor Speed		CFM Wet Coil without filter and Electric Heat								
				External Static Pressure-Inches W.C.[kPa]								
				0[0]	0.1[.025]	0.2[.050]	0.3[.075]	0.4[0.100]	0.5[0.125]	0.6[0.150]	0.7[0.175]	0.8[0.200]
48	3.5	Low	CFM	1336	1310	1282	1234	1182	1140	1049	925	833
			Watts	492	483	474	463	452	443	422	393	374
			Current/A	2.24	2.22	2.17	2.13	2.1	1.93	2.03	1.9	1.87
		Medium	CFM	1654	1610	1569	1510	1461	1394	1350	1265	1034
			Watts	550	537	526	512	503	489	475	458	416
			Current/A	2.4	2.38	2.35	2.32	2.3	2.18	2.16	2.08	2.04
		High	CFM	1918	1875	1817	1771	1715	1651	1584	1511	1395
			Power/W	717	703	686	670	652	635	617	600	570
			Current/A	3.2	3.18	3.14	3.1	3.04	3	2.9	2.87	2.85
48	4	Low	CFM	1336	1310	1282	1234	1182	1140	1049	925	833
			Watts	492	483	474	463	452	443	422	393	374
			Current/A	2.24	2.22	2.17	2.13	2.1	1.93	2.03	1.9	1.87
		Medium	CFM	1654	1610	1569	1510	1461	1394	1350	1265	1034
			Watts	550	537	526	512	503	489	475	458	416
			Current/A	2.4	2.38	2.35	2.32	2.3	2.18	2.16	2.08	2.04
		High	CFM	1918	1875	1817	1771	1715	1651	1584	1511	1395
			Power/W	717	703	686	670	652	635	617	600	570
			Current/A	3.2	3.18	3.14	3.1	3.04	3	2.9	2.87	2.85
60	5	Low	CFM	1726	1693	1655	1637	1584	1500	1421	1328	1217
			Watts	678	658	639	619	602	576	553	526	495
			Current/A	2.95	2.87	2.78	2.69	2.62	2.52	2.42	2.31	2.18
		Medium	CFM	1983	1933	1879	1828	1760	1685	1597	1507	1403
			Watts	695	675	655	635	615	596	574	550	522
			Current/A	3.02	2.93	2.85	2.76	2.67	2.59	2.5	2.4	2.28
		High	CFM	2138	2086	2024	1952	1873	1797	1722	1646	1516
			Power/W	793	773	751	726	702	679	658	638	604
			Current/A	3.45	3.7	3.27	3.17	3.06	2.97	2.88	2.79	2.65

--- Shaded boxes represent airflow outside the required 300-450 cfm/ton, which are not recommended.

NOTES: Airflow based upon cooling performance at 230V with no electric heat and no filter.

The air distribution system has the greatest effect on airflow. The duct system is totally controlled by the contractor. For this reason, the contractor should use only industry-recognized procedures.

Heat pump systems require a specified airflow for electric heat operating. Each ton of cooling requires between 350 and 450 cubic feet of air per minute (CFM), or 400 CFM nominally.

Duct design and construction should be carefully done. System performance can be lowered dramatically through bad planning or workmanship.

Air supply diffusers must be selected and located carefully. They must be sized and positioned to deliver treated air along the perimeter of the space. If they are too small for their intended airflow, they become noisy. If they are not located properly, they cause drafts. Return air grilles must be properly sized to carry air back to the blower. If they are too small, they also cause noise.

The installers should balance the air distribution system to ensure proper quiet airflow to all rooms in the home. This ensures a comfortable living space.

An air velocity meter or airflow hood can be used to balance and verify branch and system airflow (CFM).

**IMPORTANT:**

1. If unit is converted to downflow, the airflow for model 18 must be between 350 and 450 cfm/ton.
2. When model 44 used for mobile home, you need to ensure that the air volume is not less than 1335 CFM.
3. When model 48 used for mobile home, you need to ensure that the air volume is not less than 1584 CFM.

## 5 Wiring Diagram

D1418HAEAL2, D1424HAEAL2, D1436HAEAL2, D1448HAEAL2, D1460HAEAL2

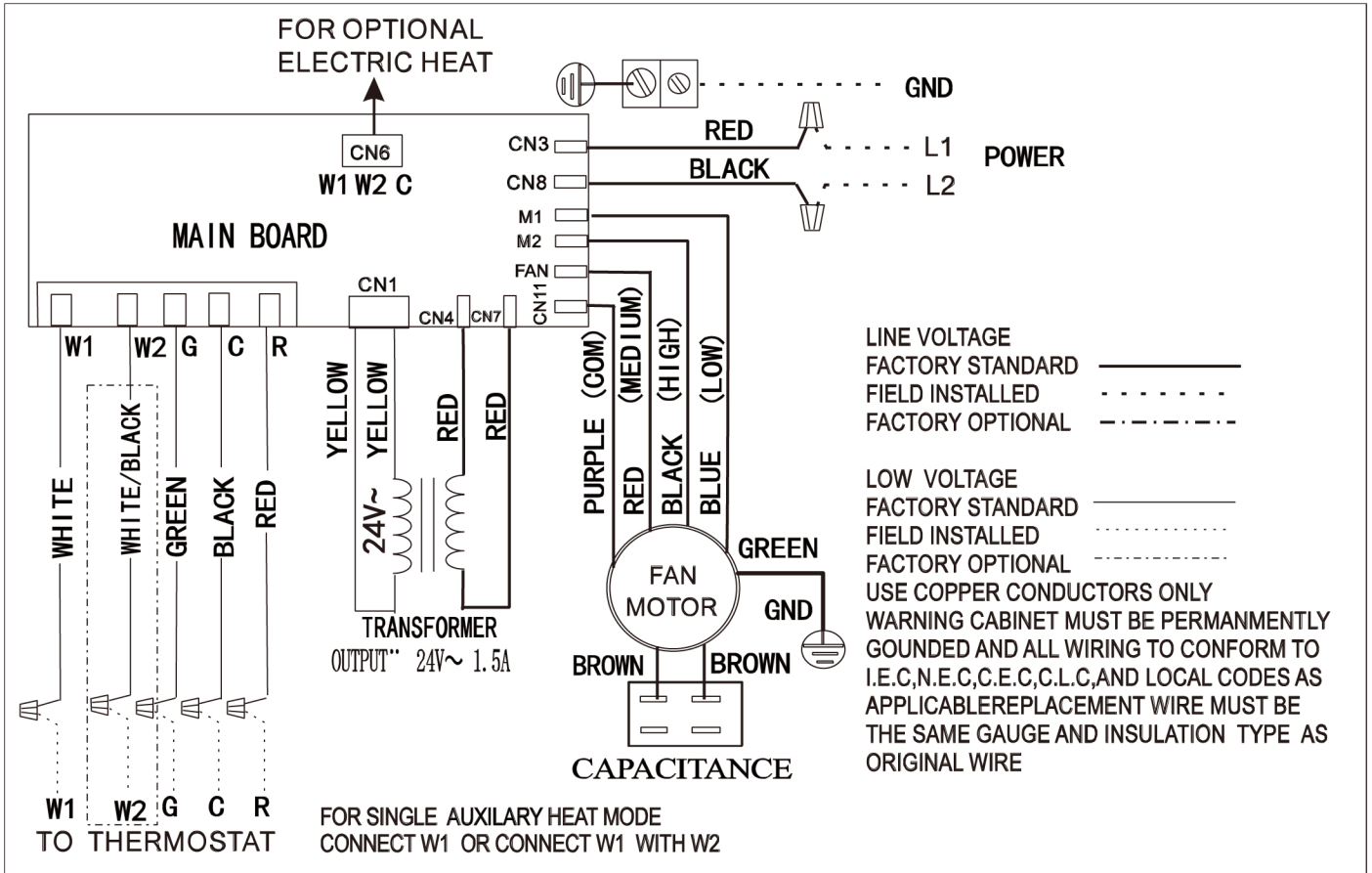

Note: Description of fan speed switch with PSC motor

1. Default as medium speed of factory settings.
2. High speed wiring: Switch to high speed (black wire) and connect with FAN terminal, while medium speed (red wire) connect with M2 terminal.
3. Low speed wiring: Switch to low speed (blue wire) and connect with FAN terminal, while medium speed (red wire) connect with M1 terminal.
4. For the 36K model (D1436HAEAL2), in order to make the AHRI 14.3 SEER2 system rating the fan speed must be changed from Medium to High.

Terminal \ Fan speed	Fan	M1	M2
Medium	Red	Blue	Black
High	Black	Blue	Red
Low	Blue	Red	Black



**6 Heater Kits**

Model	Air Handler Capacity (kBTU/h)	Electric Heat(kW)	Min. Circuit Ampacity		Max. Fuse or Breaker (HACR) Ampacity		Fan speed (AC/HP)		
			240V	208V	240V	208V	Low	Medium	High
D1418HAEAL2 EHK-05A(UL) EHK-08A(UL) EHK-10A(UL)	18	5	28.1	24.6	30	25		●	●
		7.5	41.1	35.9	45	40	●	●	●
		10	54.1	47.2	60	50	●	●	●
D1424HAEAL2 EHK-05A(UL) EHK-08A(UL) EHK-10A(UL)	24	5	29	25.5	30	30	●	●	●
		7.5	42	36.8	45	40	●	●	●
		10	55	48.1	60	50	●	●	●
D1436HAEAL2 EHK-05A(UL) EHK-08A(UL) EHK-10A(UL) EHK-15B(UL)	30	5	29.4	25.9	30	30	●	●	●
		7.5	42.4	37.2	45	40	●	●	●
		10	55.4	48.5	60	50		●	●
		15	55.4/26.1	48.5/22.6	60/30	50/25	●	●	●
D1436HAEAL2 EHK-05A(UL) EHK-08A(UL) EHK-10A(UL) EHK-15B(UL) EHK-20B(UL)	36	5	29.4	25.9	30	30	●	●	●
		7.5	42.4	37.2	45	40	●	●	●
		10	55.4	48.5	60	50	●	●	●
		15	55.4/26.1	48.5/22.6	60/30	50/25	●	●	●
		20	55.4/52.1	48.5/45.2	60/60	60/50	●	●	●
D1448HAEAL2 EHK-05A(UL) EHK-08A(UL) EHK-10A(UL) EHK-15B(UL) EHK-20B(UL)	42	5	30.3	26.8	35	30	-	●	●
		7.5	43.3	38.1	45	40	-	●	●
		10	56.3	49.4	60	50	-	●	●
		15	56.3/26.1	49.4/22.6	60/30	50/25	-	●	●
		20	56.3/52.1	49.4/45.2	60/60	50/50	-	●	●
D1448HAEAL2 EHK-05A(UL) EHK-08A(UL) EHK-10A(UL) EHK-15B(UL) EHK-20B(UL)	48	5	30.3	26.8	35	30	-	-	●
		7.5	43.3	38.1	45	40	-	-	●
		10	56.3	49.4	60	50	-	-	●
		15	56.3/26.1	49.4/22.6	60/30	50/25	-	-	●
		20	56.3/52.1	49.4/45.2	60/60	50/50	-	-	●
D1460HAEAL2 EHK-05A(UL) EHK-08A(UL) EHK-10A(UL)	60	5	31.8	28.3	35	30	●	●	●
		7.5	44.8	39.6	45	40	●	●	●
		10	57.8	50.9	60	60	●	●	●

# D14 Series



EHK-15B(UL)	60	15	57.8/26.1	50.9/22.6	60/30	60/25	●	●	●
EHK-20B(UL)		20	57.8/52.1	50.9/45.2	60/60	60/50	●	●	●

NOTE: HEATER MODEL NUMBER DIGITS "\*" : A,B

Heat kit suitable for AHU 4-way position installation.

Ampacities for MCA and Fuse/breaker including the blower motor.

Heat pump systems require a specified airflow. Each ton of cooling requires between 350 and 450 cubic feet of air per minute (CFM), or 400 CFM nominally.

## Electric Heater Kits

NO.	Kit	Description	Ref.Air Handler Use
1	EHK-05A(UL)	5kW Heat Strip	18/24//30/36/42/48/60
2	EHK-08A(UL)	7.5kW Heat Strip	18/24//30/36/42/48/60
3	EHK-10A(UL)	10kW Heat Strip	18/24//30/36/42/48/60
4	EHK-15B(UL)	15kW Heat Strip, double Breaker panel	30/36/42/48/60
5	EHK-20B(UL)	20kW Heat Strip, double Breaker panel	36/42/48/60

NOTE: HEATER MODEL NUMBER DIGITS "\*" : A,B

Electric Heat Kit Wiring Diagram

